

Quantum dot cellular automata: A new paradigm for digital design

Bisma Bilal, Suhaib Ahmed*, Vipin Kakkar

Department of Electronics and Communication Engineering, Shri Mata Vaishno Devi University, Katra, J&K - 182 320, India.

*) E-mail: sabatt@outlook.com



Received 19/9/2018, Accepted 29/12/2018, Accepted 15/1/2019

Quantum Dot Cellular Automata (QCA) is a newly developed paradigm for digital design, which holds the potential to be the possible alternative to the present CMOS (Complementary Metal Oxide Semi-Conductor) technology. After surviving for nearly five decades, the scaling of CMOS is finally reaching its limits. The asperities are not only seen from the physical and technological viewpoint but also from the material and economical perspectives. With no more scaling possible, there arises a need to look for promising alternatives to continue with the nano size/scale computations and to hold on to the Moore's law. QCA offers a breakthrough required for the fulfilment of certain lacking aspects of CMOS technology in the nano regime. QCA is a technology that involves no current transfer but works on electronic interaction between the cells. The QCA cell basically consists of quantum dots or metal islands separated by certain distance and the entire transmission of information occurs via the interaction between the electrons localized in these potential wells. Since the technology is new and in a premature phase, a huge scope lies ahead of the researchers to investigate and make QCA designing a reality. In this paper the QCA technology is reviewed with sufficient focus on basic concepts, implementations and information flow. The various building blocks in QCA are discussed and their working on the basis of physical laws is explained. This paper forms the basis for further complex digital designing in QCA.

Keywords: QCA; Cellular Automata; CMOS; Nanotechnology; Low Power.

1. INTRODUCTION

CMOS is a technology which has revolutionized the world of electronics. Invented over forty years ago, the device today has shrunk to many orders of magnitude. It is this miniaturization that has resulted in a continued progress in terms of cost, performance and energy efficiency. A number of reasons contribute in making CMOS the best at hand for microelectronics, some of which include the better possible scalability, current dependence on channel width instead of emitter area, low power consumption etc. [1,2,3].

The downsizing per component in VLSI has been possible due to extensive scaling of the basic MOS device. The concept of scaling proposed by Dennard [25] has been the driving force behind the miniaturization success achieved in the MOSFET. The Moore's prediction of components on an IC doubling every 18 months has survived for more than the anticipated time but now an era has started where in the applicability of mosfet is facing practical limits around the gate length of less than 30nm. As the device enters the nano regime (<100nm) the scaling reaches its upper limit and the conventional classical laws are no longer applicable. The various quantum mechanical effects begin to dominate as the size of the basic component approaches that of a single atom. The effort towards the continuation of the device miniaturization involves two aspects. The first one is the development of the CMOS based devices that extend to 3D or vertical dimension and improving material technology etc. [5]. The second is the development of the alternative to replace CMOS. The transition towards a new paradigm of computing may not take years but decades of continued effort and it is the high time for the researchers to grow this foundation for moving towards the next generation computer architectures.

One of the promising alternatives to CMOS technology is the Quantum Dot Cellular Automata proposed by Lent [6]. It introduces the concept of implementation of cellular automata using nano size structures like quantum dots. The basis of QCA lies in the physics of interaction between the electrons placed in the potential wells. Quantum dots form one choice of nano structures to be used in QCA. Quantum Dots are tiny crystals made of semiconductor material and are approximately ten thousand times narrower than human hair. Due to the advantage of ultra-low size, QCA technology holds a strong position as an alternative to CMOS technology [8]. The basic QCA cell consists of a finite number of these quantum dots or metal islands in which the electrons can localize. Precisely a QCA cell contains $2N$ dots where N is the number of electrons which can tunnel between the quantum dots. However there can be no tunneling between the cells due to the high potential barrier. In other words we can say that the potential wells within a cell are connected by tunnel junctions which can be opened for transport of electrons [9]. The structure of the basic QCA cell is shown in figure 1.

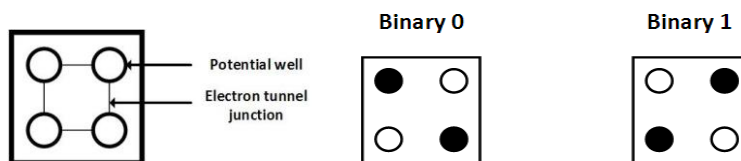

Figure 1 Basic QCA Cell and possible alignments of electrons

The working mechanism of QCA is based on the principle of quantum mechanical tunneling between the electrons localized in the wells and the coulombic interaction between the electrons. The alignment of the electrons in the QCA cell is governed by the coulomb's law according to which the electrons tend to occupy the positions with maximum separation due to coulombic repulsion between them [10]. This can be conceptually understood by considering the possible alignments of electrons in the cell. Since the QCA cell is a square structure the two possible polarizations are as shown in figure 1. The polarization of -1.00 represents a binary 0 and the polarization of $+1.00$ represents a binary 1. These are the only two possible configurations of the electrons because all other positions of electrons lead to maximum repulsion as shown in the figure 2.

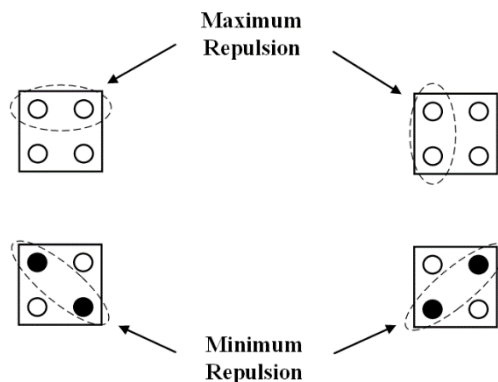

Figure 2 Maximum and minimum repulsion positions of electrons in QCA cell

This possibility of two states (polarizations) provides an opportunity for information to be encoded and transferred using QCA cells [14]. The two QCA cells which are placed next to each other can exchange states by adjusting the position of electrons such that to overcome the coulombic repulsion between them. The cell which has to transfer its state to the adjacent cell must have closed tunnel junctions whereas the cell which has to change its state must have open junctions to allow electrons to adjust positions. The state of a particular cell is transferred to all the cells connected to it provided the tunnel junctions of the latter are opened. The QCA follows the phenomena of memory in motion and processing in wire which means that the interconnections and the circuits are made up of the same cells unlike other technologies like the CMOS technology where interconnections have their own set of principles and designs. QCA exploits the interaction of polarizations for effective Boolean logic implementations. One important aspect in QCA cell polarization is that even a slight polarization in a neighboring cell induces complete polarization in the target cell which means that at every stage or cell the signal level is restored. This gives an additional advantage of repeater less circuits in QCA. The QCA cells in various arrangements can be used for designing digital circuits which are the basic building blocks in the computer architecture and arithmetic circuits.

2. BASIC BUILDING BLOCKS IN QCA

The first step towards the approach of designing a complete system using QCA is to come up with the basic building block designs. These basic designs help in easy understanding of the mechanism of working and interaction between the cells. These blocks in QCA are binary wire, inverter and majority gate [11]. These basic designs are discussed below:

2.1 Binary Wire

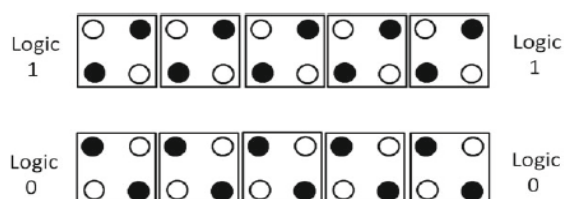

Figure 3 Binary Wire

The binary wire as shown above transfers the state of the input cell to the output which forms the core concept in digital designing i.e. transferring input to output. The concept of the wire is the coulomb's law because of which the electrons of the adjacent cells are arranged according to the input cell in order to avoid repulsion due to electrostatic forces. For example if the input cell has a polarization of -1.00, i.e. it is logic 0 then the adjacent cells follow the same alignment to achieve the state of maximum stability. The implementation of Binary wire is done on QCA designer 2.0.3 software tool [13] and correct results have been obtained which are shown in the simulation waveform in figure 4.

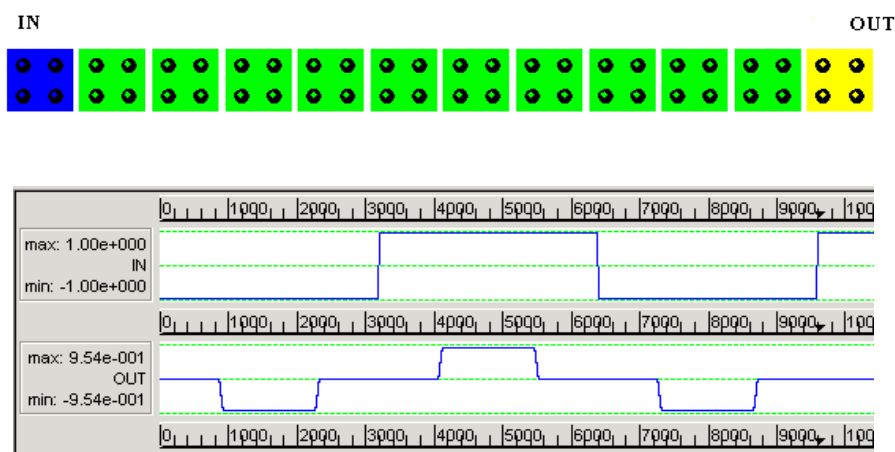

Figure 4 Binary wire implementation and simulation result in QCA Designer 2.0.3

2.2 Inverter

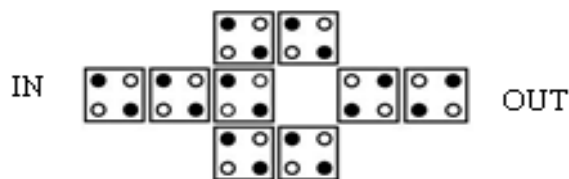

Figure 5 QCA Inverter

The inverter as shown above works because of the inversion of the electron alignment due to coulombic repulsion at the corner cell. This is because the same polarization as the input will lead to maximum repulsion and instability and thus the electrons anti align themselves with respect to the input cell. This is one of the basic designs of the inverter in which the corner cell is oriented at 45 degree with respect to the other cells. A number of other designs have been suggested by researchers from time to time but this design finds applicability in most of the circuits. The inverter was simulated in QCA designer 2.0.3 to obtain the results as shown in figure 6.

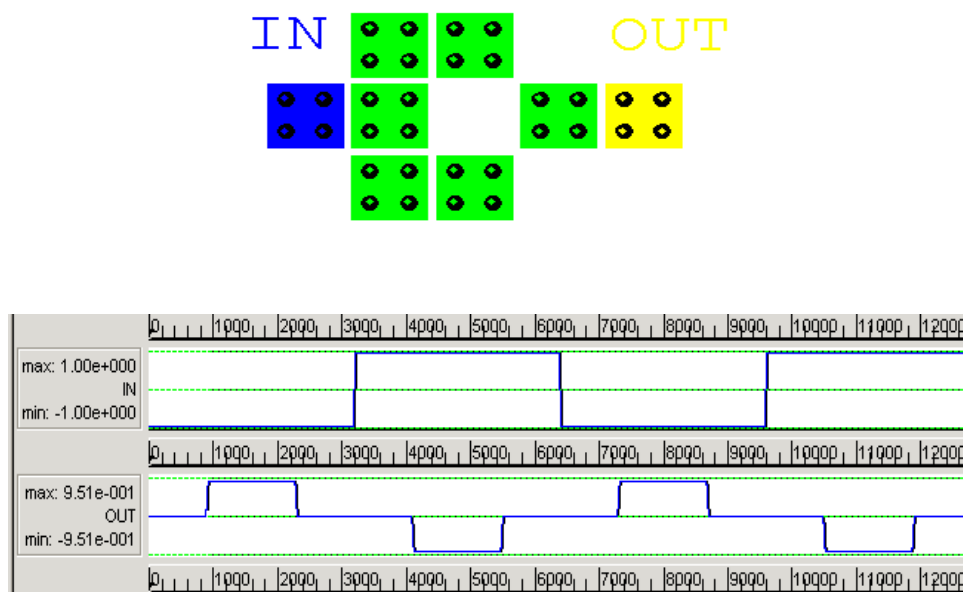

Figure 6 Inverter Implementation and simulation results in QCA Designer 2.0.3

2.3 Majority Voter

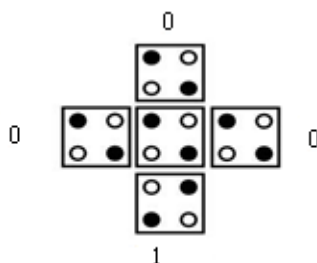
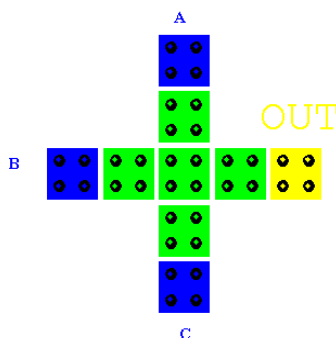

Figure 7 QCA Majority Voter

The other important gate in QCA is the majority voter (c). This gate sets the value of the output cell on the basis of the polarization of majority of the inputs because that provides a ground state for the device cell (central cell). The majority gate implements the equation $AB+BC+AC$ where A, B, C are the inputs.



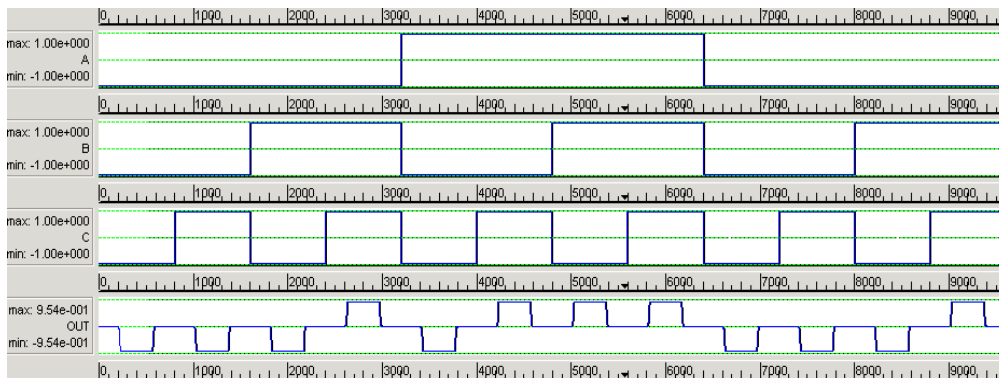

Figure 8 Majority Voter Implementation and simulation results in QCA Designer 2.0.3

The majority gate can be used for the implementation of AND and OR gate by applying fixed polarization to one of the inputs. When the input polarization is fixed to 1.00 (logic 1) the majority voter acts as an OR gate and when the polarization is fixed to -1.00 (logic 0) the gate acts as an AND gate [12]. The AND gate shown has the input 1 and 0 for the shown case below (evident from the cell polarization). For the OR gate we have considered both inputs to be 0. The gate can similarly be verified for other combinations. The basic NAND and NOR can be implemented by using an inverter at the output of the AND and OR gate respectively. All these designs are shown in figure 9.

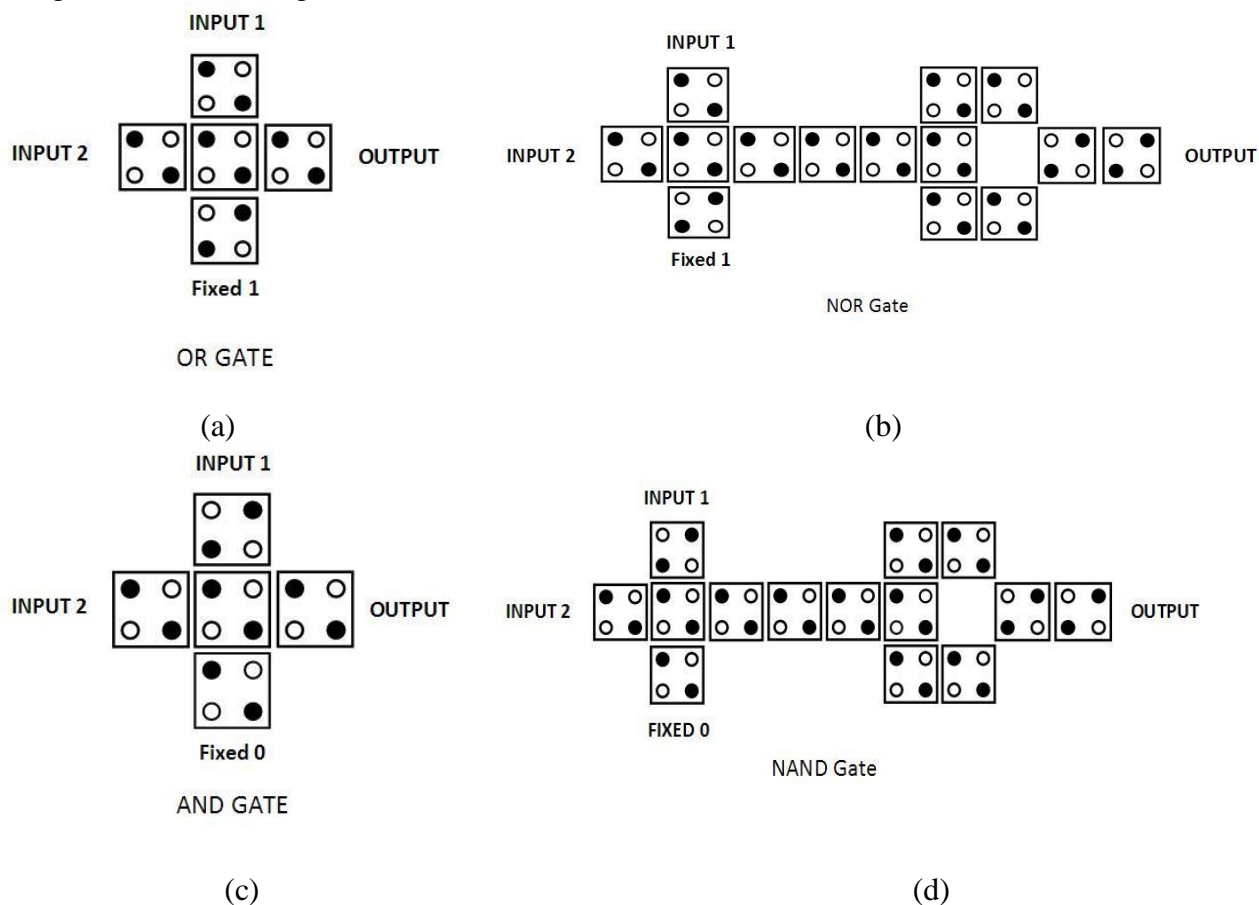

Figure 9 (a) OR Gate (b) NOR Gate (c) AND Gate (d) NAND Gate implementation using majority gate

3. CLOCKING IN QCA

The structures (building blocks) which we have discussed till now are all asynchronous structures and input is the only source of energy. As a result of this there is no control over switching [10]. When the input is applied to the array of QCA cells the basic mechanism involves the change of the state of cells from ground state to excited state [15]. This array is expected to settle into a new ground state. However, in the absence of the clock the cells may have a transition to a new metastable state which may result in an unpredictable operation. This can be overcome by the clocking of QCA cells. The clocking is basically for the control of barriers between the dots which in turn controls the transfer of electrons. The QCA clocking scheme consists of four phases – switch phase, hold phase, release phase and the relax phase. The phases are shown in figure 10.

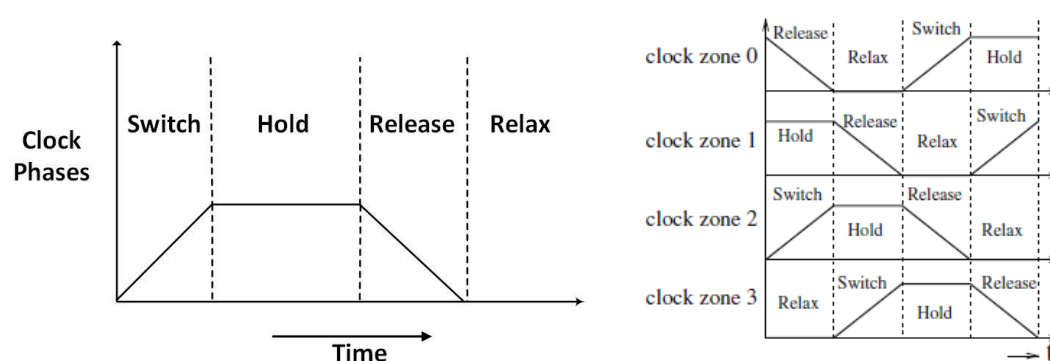

Figure 10 Different Clock Phases and clock zones in QCA

In QCA four clocking zones are used. The cells are arranged in zones so that the field remains the same in all the cells in the zone. The concept lies in the radius of effect of each electron i.e. electron can have the effect of its charge up to a certain radius. It is the method of clocking that makes QCA different from CMOS devices.

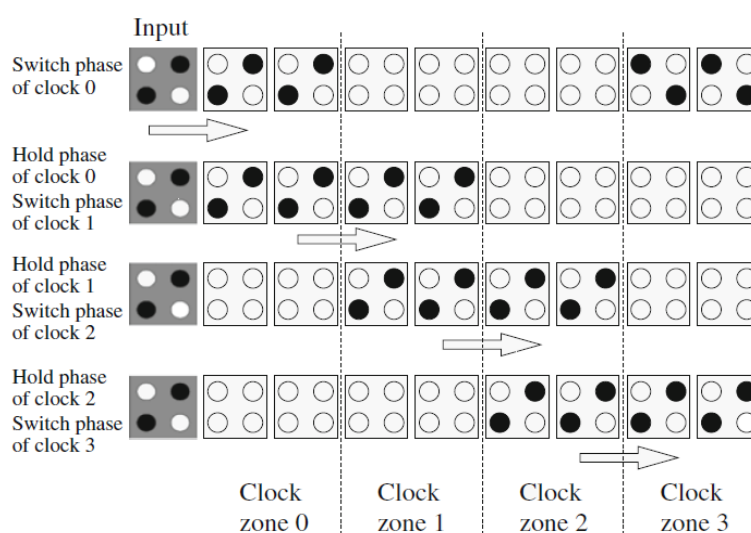

Figure 11 Illustration of clocking in QCA Cells

The clocking in QCA is provided by the underlying CMOS or carbon nanotube wires which provide the necessary electric field to raise or lower the tunnel barrier for the movement of the electrons between them. Also, we know that the cells in the same clock zone have the same potential of the tunnel junctions i.e. either they all have raised barriers or lowered barriers, so based on the adjacent cell state the cells take up the polarization. This leads to proper flow of information in QCA via pipelining. The various phases of the clock need to follow each other in a proper sequence in order to proliferate the output to correct values. The various phases of the clock are discussed next.

Initially the cells have low potential barriers and are in the unpolarized state. During the switch phase of the clock cycle the cell is influenced by the neighboring cell polarization which causes it to take up a new state. After achieving the new polarization due to the neighboring cell the barriers between the dots are raised such that no further change of state can occur. During the hold phase the cell holds the state and barriers are maintained high. In this phase the cells act as input to the neighboring cells. In the release and relax phase the barriers between the dots are lowered which results in the loss of polarisation due to tunneling of electrons and cell again has a null polarization now. The different clock zones in QCA are represented by different colors e.g. clock zone 0 is represented by green, clock zone 1 by magenta, clock zone 2 by blue and clock zone 3 by white. All the complex designs use the clocking phenomena for proper flow of information via pipelining. [22-24] The clocked basic wire in QCA is shown in figure 12.

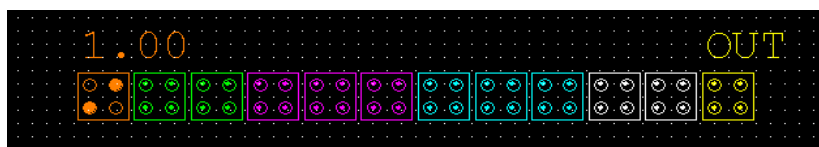

Figure 12 Clocked QCA wire

Just like we have designed a wire using all four clock phases, other digital circuits can be designed as well. It has been suggested that at least four cells should be placed in one clock phase for proper information flow. More complex the design of a digital circuit more attention is needed in proper clocking of the circuit. The various optimization parameters in QCA circuits are the cell count, cell area, total area, latency and complexity of the designs.

4. QCA CROSSOVERS

Many a times the circuit designs involve crossing over of the QCA wires for less complex design to be implemented. In QCA two main types of crossovers have been identified. One is the coplanar crossover in which simple and rotated cells are used to cross as there is no interaction between the two. The other is the multilayer crossover which involves more than one layer of cells, similar to routing of metal wires in CMOS technology. The design and implementation of multilayer crossover is however more complicated than the coplanar one and also involves higher cost consideration. The various types of combinational and sequential circuits that are designed using Quantum Dot Cellular Automata use the crossovers for optimization of circuits by reducing the cell count and area. The reduction in cells further leads to the reduction in the overall power dissipation. [16-20]. The two types of crossovers in QCA are as shown in the figure 13.

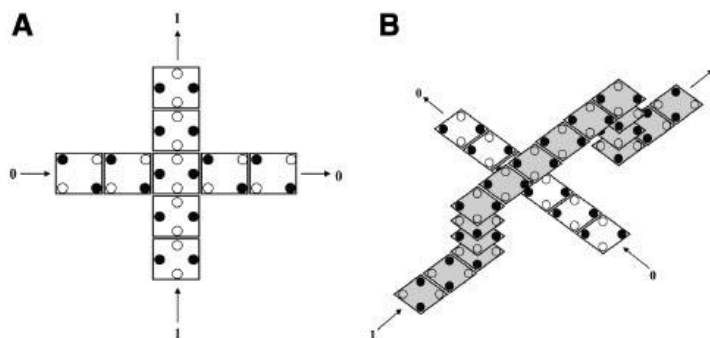

Figure 13: (A) Coplanar Crossover

(B) Multilayer Crossover

5. ADVANTAGES OF QCA

The possibility of continuity with CMOS still exists but it is the cost to benefit ratio that motivates the researchers to shift their attention towards the development of alternatives to CMOS technology. The QCA technology discussed in this paper is one such alternative. The main advantages of QCA over the other possible alternatives are the high density circuits that it allows. Due to small size of quantum dots or metal islands which are used as potential wells, very compact arrangements are possible which further reduce the overall size and delay of the circuits. Another very important advantage of the QCA circuits is the low power consumption. This occurs since in QCA there is no current flow between the cells. Only the alignment of electrons is manipulated. It therefore seems appropriate for design of circuits for general-purpose computation as well as for embedded applications. The unique feature of QCA clocking provides the provision of signal gain and pipelining for the realization of efficient logic structures.

6. FUTURE SCOPE

Presently QCA technology is in a very premature phase but is one of the strongest contenders to replace CMOS in the next few decades. According to International Technology and Roadmap for Semiconductors ITRS, the CMOS technology has now started to face asperities in maintaining the miniaturization criterion and holding on to the Moore's law which has resulted in the development of interest of the researchers in suitable replacement of the CMOS. However, the requirement is not only to find the alternative, but to choose the best possible substitute which takes the size, power and speed into consideration. Having discussed the advantages of QCA in the last section we see that QCA offers a firm furtherance. Currently only a few implementations in QCA have been experimentally verified and it has been pointed out that the main issue with the designing is that the cells require ultra-low temperature for proper working. This has suggested for the molecular QCA (MQCA) designing in which the redox centers in the molecules can be the places where the electrons can localize. MQCA eliminates the need of ultra-low non feasible temperature for designing using QCA.

Various implementations of digital circuits have been shown in QCA using various designer tools and results have been verified. These include the designs of various combinational and sequential circuits [30-32]. In digital circuits clocking is required only in sequential circuits whereas in QCA circuits both combinational and sequential circuits require appropriate clocking mechanisms to allow proper information flow. This is because the state and polarization of each

cell is important as it governs the state of the next cell. A new field of designing in QCA is the upcoming logic in digital design which is called as the reversible logic. Reversible logic suggests that the power is dissipated in the circuits due to the erasing of the bits during computation. This principle was given by Landauer. It suggests that for every bit that is erased $kT \ln 2$ joules of energy is dissipated. If these computations are somehow performed in a reversible manner that is without the erasing of the bits the power dissipation can be reduced to a great extent [26-29]. However the design of the reversible circuits has been the greatest challenge faced by the researchers. QCA is suggested as the break through by which these circuits can be implemented. Reversible logic along with QCA technology if accomplished will result in ultra-small devices and ultra-low power dissipation.

7. CONCLUSIONS

In this paper the basics of Quantum Dot Cellular Automata are reviewed starting from the basic QCA cell. Further various building blocks which form the basis of all the complex digital designs in QCA and the mechanism for clocking is discussed. The basic block schematics are simulated using QCA designer 2.0.3 software to verify the results. It is envisaged that various complex digital circuits can be designed in QCA and further optimization can be achieved such as reduction in the cell count and area. The future scope of QCA in designing combinational, sequential and reversible logic circuits has been discussed. It is concluded that QCA has called for much attention in the recent years and needs proper research to give technology a new dimension, different from the conventional transistor-based designing.

References

- [1] J. Gautier, Beyond CMOS: quantum devices”, *Microelectronic Engineering*, 39 (1997) 263
- [2] H. Iwai, End of the scaling theory and Moore's law, *Proc. of 16th IEEE International Workshop on Junction Technology*, (2016) 1
- [3] D. Bishop, Nanotechnology and end of Moore's law, *Bell Labs Technical Journal*, 10 (2005) 23
- [4] Ahmed M. A. Hassan, Moustafa Ahmed, M. Nakahama, Fumio Koyama, *Exp. Theo. NANOTECHNOLOGY 2 (2018) 91*
- [5] J. M. Shalf, Robert Leland, Computing beyond Moore's Law, *Computer*, 48 (2015) 14
- [6] C.S Lent, P. D. Tougaw, W. Porod, G. H. Bernstein, *Quantum Cellular Automata, Nanotechnology*, 4 (1993) 49
- [7] B. Krishan, M. R. Garg, A Literature Review on Quantum Dots, *International Journal of Advanced Research in Electrical, Electronics and Instrumentation Engineering*, 4 (2015). 7857
- [8] Y. B. Kim, Challenges for nanoscale MOSFETs and emerging nanoelectronics, *Transaction on Electrical and Electronic Materials*, 11 (2010) 93
- [9] W. Porod, Quantum-dot devices and quantum-dot cellular automata, *International Journal of Bifurcation and Chaos*, 7 (1997) 1147
- [10] P. Kumari, K. S.Gurumurthy, Quantum dot cellular automata: a review”, *Proc. of the IEEE International Conference on Advances in Computing and Information Technology*, (2014) 51
- [11] M. Mourad Mabrook, *Exp. Theo. NANOTECHNOLOGY 2 (2018) 103*
- [12] L. Balakrishnan, T. Godhvari, S. Kesavan, Effective design of logic gates and circuit using quantum cellular automata (qca), *Proc. of IEEE International Conference on Advances In Computing, Communications And Informatics*, (2015) 457
- [13] K. Walus, T. J. Dysart, G. A. Jullien, R. A. Budiman, QCADesigner: A Rapid Design and Simulation Tool for Quantum-Dot Cellular Automata, *IEEE Transactions on Nanotechnology*, 3 (2004). 26

- [14] C. S. Lent, P. D. Tougaw, W. Porod, Bistable saturation in coupled quantum dots for quantum cellular automata, *Applied Physics Letters*, 62 (1993) 714
- [15] S. Singh, S. Pandey, S. Wairy , Modular Design of 2n:1 Quantum Dot Cellular Automata Multiplexers and its Application via Clock Zone based Crossover, *International Journal of Modern Education and Computer Science*, 7 (2016) 41
- [16] R. Devadoss, K. Paul, M. Balakrishnan, Coplanar QCA crossovers, *Electronics Letters*, 45 (2009) 1234
- [17] K. Makanda, J. C. Jeon, Combinational circuit design based on quantum dot cellular automata, *International Journal of Control and Automation*, 7 (2014) 369
- [18] H. S. Jagarlamudi, M. Saha, P. K. Jagarlamudi, Quantum dot cellular automata based effective design of combinational and sequential logical structures, *International Journal of Computer, Electrical, Automation, Control and Information Engineering* 5 (2011) 1529
- [19] M. M. Arjmand, M. Soryani, K. Navi, Coplanar wire crossing in quantum cellular automata using a ternary cell, *IET Circuits, Devices & Systems*, 7 (2013) 263
- [20] D. Abedi, G. Jaberipur, M. Sangsefidi, Coplanar full adder in quantum-dot cellular automata via clock-zone-based crossover, *IEEE transactions on nanotechnology* 14 (2015) 56
- [21] R. Devadoss, K. Paul, M. Balakrishnan, Clocking-Based Coplanar Wire Crossing Scheme for QCA, *Proc. of 23rd IEEE International Conference on VLSI Design*, (2010) 339
- [22] M. Liu, C. S. Lent, Bennett and Landauer clocking in quantum-dot cellular automata, *Proc. of 10th International Workshop on Computational Electronics*, (2004) 120
- [23] C. S. Lent, B. Isaksen, Clocked molecular quantum-dot cellular automata, *IEEE Transactions on Electron Devices*, 50 (2003) 1890
- [24] A. O. Orlov, G. Toth, I. Amlani, R. Kummamuru, R. Ramasubramaniam, C. S. Lent, G. H. Bernstein, G. L. Snider, Experimental studies of clocked quantum-dot cellular automata devices, *Proc. of 58th Device Research Conference*, (2000) 157
- [25] R.H.Dennard et.al, "Design of Micron MOS Switching Devices", *Proc. Of IEEE intl. Electron Devices Meeting*, (1972)
- [26] R. Landauer, "Irreversibility and Heat Generation in the Computing Process", *IBM Journal of Research and Development*, 5 (1961) 183
- [27] C.H.Bennett , "Logical Reversibility of Computation", *IBM Journal of Research and Development* 17, (1973) 525
- [28] R. Feynman, "Quantum Mechanical Computers," *Optical New*, (1985)11
- [29] M. R. Beigh, M. Mustafa, "Design and Analysis of a Simple D Flip-Flop Based Sequential Logic Circuits for QCA Implementation", *Proc of IEEE Conference on Computing for Sustainable Global Development (2014)*
- [30] Keivan Navi, RaziehFarazkish , SamiraSayedsalehi , Mostafa Rahimi Azghadi , "A new quantum dot cellular automata full-adder", *Microelectronics Journal*, 41 (2010) 820
- [31] Dariush Abedi, Ghassem Jaberipur, and Milad Sangsefidi, "Coplanar full adder in quantum-dot cellular automata via clock-zone-based crossover", *IEEE transactions on nanotechnology*, 14 (2015) 497
- [32] Abbas Shahini Shamsabadi , Behrouz Shahgholi Ghahfarokhi, , Kamran Zamanifar , Naser Movahedinia, "Applying inherent capabilities of quantum-dot cellular automata to design: D flip-flop case study", *Journal of Systems Architecture*, 55 (2009) 180

